



# NU120 / NU170 / NU200



## Features

- Gas, steam, electrical heating (NU120)
- Large door opening for easy loading and unloading (Ø68cm)
- Galvanized drum
- Radial airflow
- Standard reversing drum
- Self-cleaning lint screen
- Preheating of intake air

## Options

- Stainless steel drum
- Stainless steel front panel
- Residual moisture control:
  - Lower energy and utility costs
  - Lower linen replacement costs
- Fire suppression system



# Dimensions & Specifications

Type		NU120 EL	NU120 GAS	NU120 STEAM (HIGH PRESSURE)	NU170 GAS	NU170 STEAM (HIGH PRESSURE)	NU200 GAS	NU200 STEAM (HIGH PRESSURE)
CAPACITY	kg	55			77		90	
DIMENSIONS DRUM		1021			1408		1656	
Drum Volume	l	Ø1118			Ø1289		Ø1289	
Drum Diameter	mm							
AIRFLOW	l/s	755			1156		1156	
HEATING	kW	60	79	119	116	190	125	190
MOTOR		0.560			0.560		0.560	
Drum	kW	0.746			2.238		2.238	
Fan	kW							
CONNECTION								
Electrical	AC/Hz	3x200-240V 50/60Hz, 3x380-415V 50Hz, 3x380-415/440V 60Hz29,9						
		Others on request			Others on request		Others on request	
Gas Inlet	inch	-	1	1	1	-	1	-
Steam Inlet	inch	1	1	3/4"	-	3/4"	3/4"	3/4"
Air Outlet	mm	254			305		305	
	inch	10			12		12	
DIMENSIONS		2177x1178x1725			2388x1349x1749		2388x1349x1939	
HxWxD Unpacked	mm	2286x1232x1829			2519x1473x1892		2515x1413x2019	
HxWxD Packed	mm							
WEIGHT								
Net	kg	578	578	624	714	760	790	820
Gross	kg	607	607	656	756	806	855	855

FRONT NU120, 170 a 200

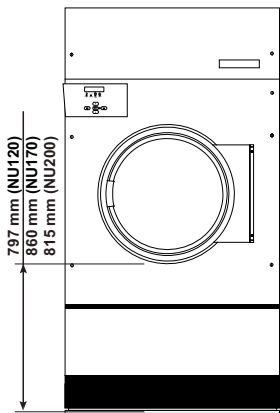

SIDE NU120, 170 a 200

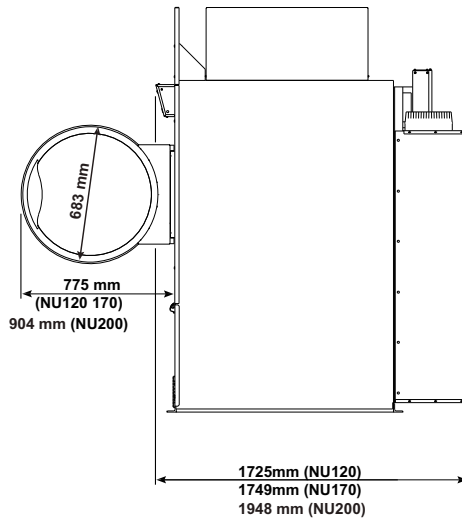

BACK NU120, 170 a 200

