



SDH10

primus

Features

- Galvanized steel cylinder
- Oversized lint filter located in front for easy cleaning
- powerful exhaust blower assures short drying times and low operating costs
- Wide door opening of 180° for easy loading and unloading
- Top, front and side panels standard available in anthracite grey
- Electrical heating
- Electronic control
- 2 digit display
- 3 auto-sensing and 3 time dry cycles
- 3 temperatures and 3 dryness levels
- Moisture level indicator
- Door open, Heating, Cooling status lights



COMPACT
DESIGN



EASY
OPERATION



Dimensions & Specifications

Type		SDH10
Capacity	kg	10
Drum Volume	l	198
Electrical Connection		1x220-240V 50/60Hz 3x380-415V+N 50Hz
Electrical Heating	kW	5,2 (230V) 5,3 (400V)
Motor Power	kW	0,25
Dimensions		
HxWxD	mm	1092x683x711
Net Weight	kg	61
Transport Data		
Volume (Packed)	m ³	0,77
Packed HxWxD	mm	1156x737x832
Gross Weight	kg	66

SDH10 Side View

SDH10 Back

SDH10 Front View

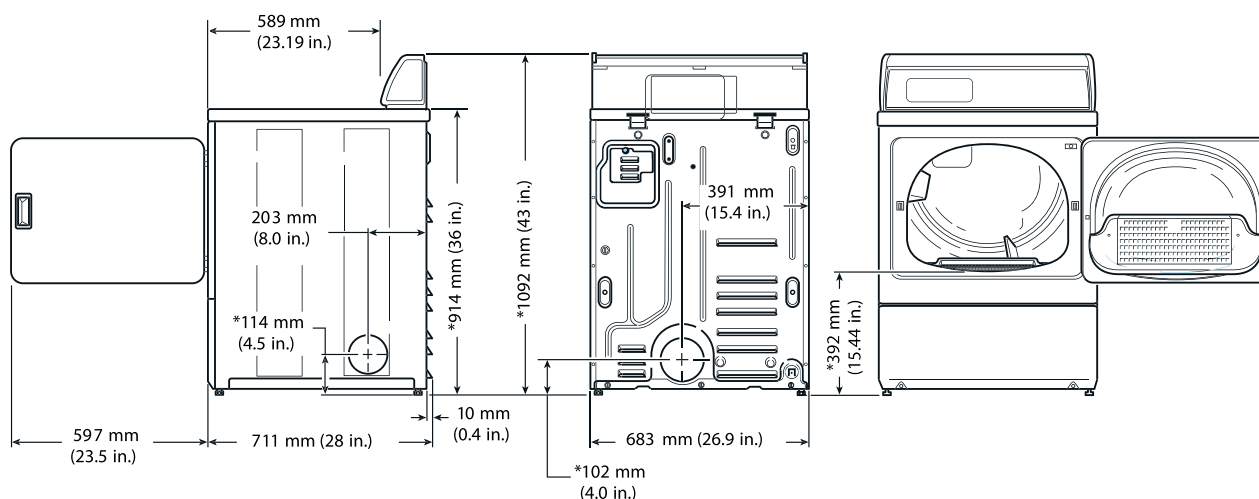

SAPPHIRE
COMMERCIAL LAUNDRY EQUIPMENT

Sales - Rentals - Parts
info@sapphirelaundry.co.uk
www.sapphirelaundry.co.uk

