



SP10 / SD10



Features – Washer Extractor

- Stainless steel outer and inner drum
- Industry-leading 440 G-Force extraction removes more moisture, minimising drying times and utility costs
- Totally freestanding: can be installed on any floor and any level
- Suspension with new out-of-balance logic
- Soap box with four compartments
- Door opens 180° for easy loading and unloading
- Standard, drain valve
- Top, front and side panels available in anthracite grey
- Electrical heating or boiler-fed
- Special mop wash programs: mops & microfibres
- LED indication of the status of the program
- Time remaining countdown
- Compact design



Features – Dryer

- Galvanized steel cylinder
- Oversized lint filter located in front for easy cleaning
- Powerful exhaust blower assures short drying times and low operating costs
- Wide door opening of 180° for easy loading and unloading
- Top, front and side panels standard available in anthracite grey
- Electrical or gas heating
- 4 drying programs
- LED indication of the status of the program
- Time remaining countdown



MOP - Range

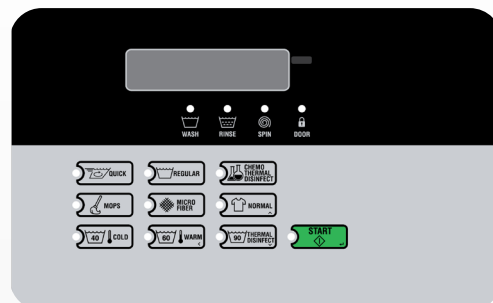

Number of Mops/batch *	SP10 MOP
Mops 100g**	90
Mops 180g**	50
Mops 200g**	45
Mops 230g**	39
Microfibre cloths 16g	563
Microfibre cloths 22g	409
Microfibre cloths 25g	350

* Numbers are indicative. Contact your Primus partner for detailed information on your requirements,

** Dimension mops 50cm x 12cm

Dimensions & Specifications

Type		SP10
CAPACITY	kg	10
DRUM VOLUME	l	96,8
MOTOR		
Frequency Controlled	kW	0,67
EXTRACTION SPEED	rpm	1200
G-FACTOR		440
ELECTRICAL CONNECTION		1x220-240V 50Hz
		1x220-240V 60Hz
		3x220-240V 50Hz
		3x380-415V+N 50Hz
ELECTRICAL HEATING	kW	4,8
DRAIN		
Drain Valve		Standard
DIMENSIONS		
HxWxD	mm	1027x683x704
Net Weight	kg	113
TRANSPORT DATA		
Volume (packed)	m ³	0,71
Packed HxWxD	mm	1150x760x860
Gross Weight	kg	122

Type		SP10
CAPACITY	kg	10
DRUM VOLUME	l	198
ELECTRICAL CONNECTION		1x220-240V 50Hz
		3x220-240V 50Hz
		3x380-415V+N 50Hz
ELECTRICAL HEATING	kW	5,2 (230V) 5,3 (400V)
GAS HEATING	kW	7,3
MOTOR POWER		0,25
DIMENSIONS		
HxWxD	mm	1027x683x711
Net Weight	kg	68
TRANSPORT DATA		
Volume (packed)	m ³	0,71
Packed HxWxD	mm	1150x760x860
Gross Weight	kg	73

* To combine with the collector it's required a base frame (200mm height) is ordered

SP10 Front View

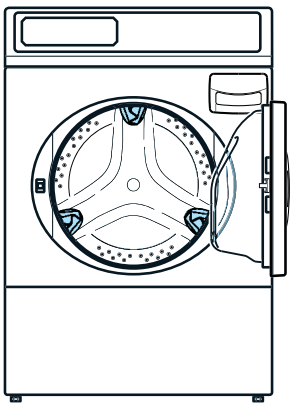

SP10 Side View

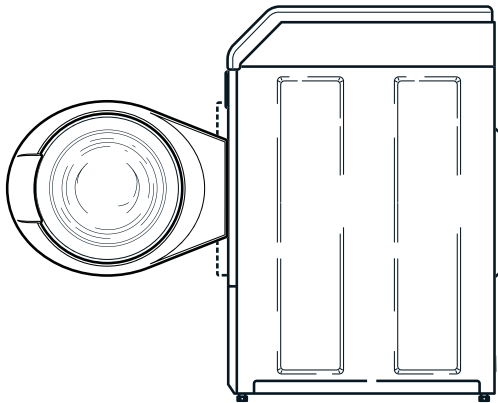

SP10 Back

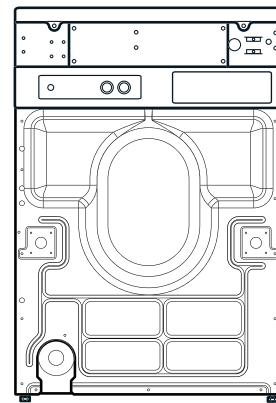

SD10 Front View

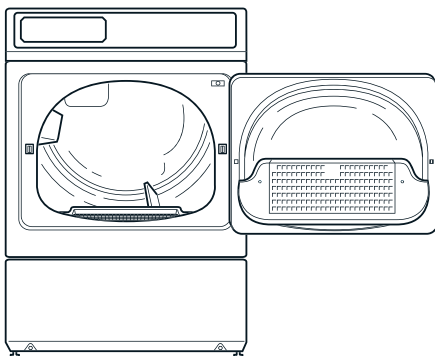

SD10 Side View

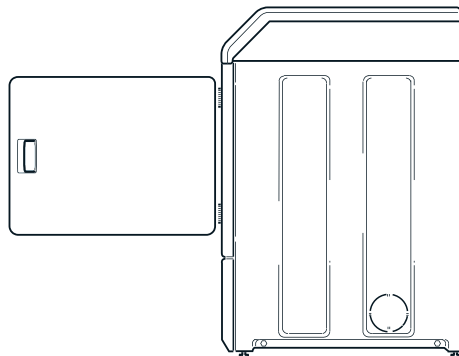

SD10 Back

