



SPC10 / SDC10

primus

Features - Washer Extractor

- Stainless steel outer and inner drum
- Industry-leading 440 G-Force extraction removes more moisture, minimising drying times and utility costs
- Totally freestanding: can be installed on any floor and any level
- Suspension with new out-of-balance logic
- Soap box with four compartments
- Door opens 180° for easy loading and unloading
- Coin boxes and coin mechanisms available as an option
- Standard with drain pump, drain valve optionally available
- Top, front and side panels standard available in anthracite grey
- Electrical heating or boiler-fed
- 6 wash programs
- Possibility of programming cycle modifier options
>> Added prewash >> Extra wash time >> Extra rinse
- LED indication of the status of the program
- Time remaining countdown



Features - Dryer

- Galvanized steel cylinder
- Oversized lint filter located in front for easy cleaning
- Powerful exhaust blower assures short drying times and low operating costs
- Wide door opening of 180° for easy loading and unloading
- Coin boxes and coin mechanisms
- Top, front and side panels standard available in anthracite grey
- Electrical or gas heating
- 4 drying programs
- LED indication of the status of the program
- Time remaining countdown



COMPACT
DESIGN



EASY
OPERATION



SUITABLE FOR
LAUNDROMATS

Dimensions & Specifications

Type		SP10
CAPACITY	kg	10
DRUM VOLUME	l	96,8
MOTOR		
Frequency Controlled	kW	0,67
EXTRACTION SPEED	rpm	1200
G-FACTOR		440
ELECTRICAL CONNECTION		1x220-240V 50Hz
		1x220-240V 60Hz
		3x220-240V 50Hz
		3x380-415V+N 50Hz
ELECTRICAL HEATING	kW	4,8
DRAIN		
Pump		Standard
Drain Valve		Available
DIMENSIONS		
HxWxD	mm	1126x683x704
Net Weight	kg	119
TRANSPORT DATA		
Volume (packed)	m ³	0,77
Packed HxWxD	mm	1150x760x860
Gross Weight	kg	128

Type		SP10
CAPACITY	kg	10
DRUM VOLUME	l	198
ELECTRICAL CONNECTION		1x220-240V 50Hz
		3x380-415V+N 50Hz
ELECTRICAL HEATING	kW	5,3 (400V)
GAS HEATING	kW	7,3
MOTOR POWER		0,25
DIMENSIONS		
HxWxD	mm	1126x683x711
Net Weight	kg	74
TRANSPORT DATA		
Volume (packed)	m ³	0,71
Packed HxWxD	mm	1150x760x860
Gross Weight	kg	79

* To combine with the collector it's required a base frame (200mm height) is ordered

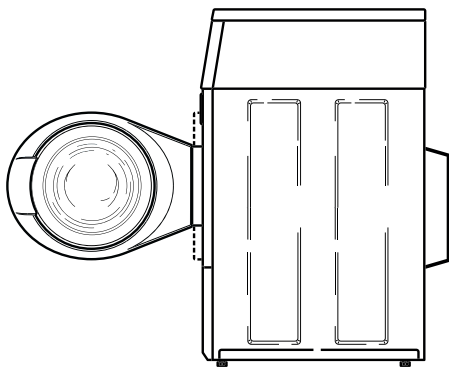

SDC10 Side View

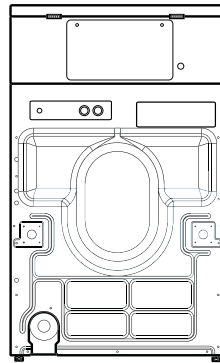

SDC10 Back

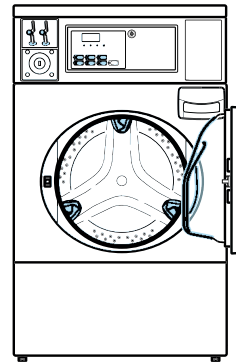

SDC10 Front View

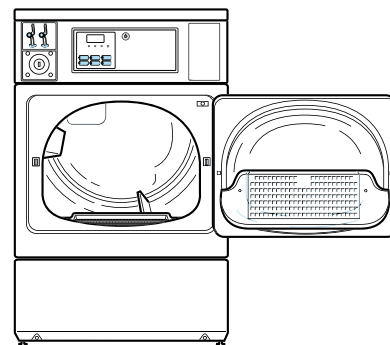
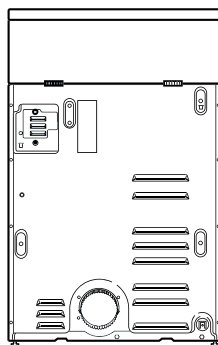
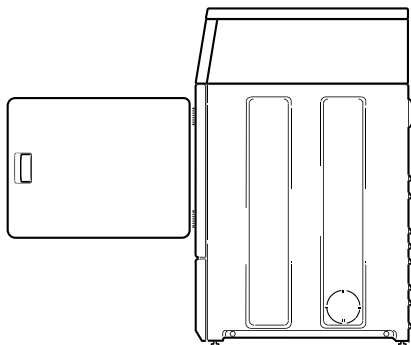

SAPPHIRE
COMMERCIAL LAUNDRY EQUIPMENT

Sales - Rentals - Parts
info@sapphirelaundry.co.uk
www.sapphirelaundry.co.uk

