



SAPPHIRE
COMMERCIAL LAUNDRY EQUIPMENT

Sales - Rentals - Parts
info@sapphirelaundry.co.uk
www.sapphirelaundry.co.uk



WF 180 / WF 240 WF 280



Features

- Freestanding, high spin
- Stainless steel top panel & anthracite grey front and side panels
- Stainless steel drum and tub
- Basic - easy-to-use microprocessor
- Patented soap hopper
- Large drain valve (Ø 76mm)
- Easy access to all vital parts from the front
- Large door opening for easy loading & unloading

Options

- Professional control - Fully programmable
- Coin operated timer (CPS)
- Stainless steel front and side panels
- USB plug (on the back panel)
- Liquid soap print (8x 24V AC Signals) - Liquid soaps connection
- Liquid soap pumps
- Water recovery kit
- Steam heating version
- High capacity water inlets (WF 180, WF 240)
- 400G FORCE (N/A FOR WF 280)



Dimensions & Specifications

Type		WF 180	WF 240	WF 280
INNERDRUM				
Maximum Capacity 1:9	kg	20	27	32
Capacity 1:10	kg	18	24	28
Volume	litres	180	240	280
Diameter	mm	750	750	750
DRUM SPEED				
Wash	rpm	42	42	42
Extraction	rpm	980	980	915
G-FACTOR		400	400	350
HEATING				
Electricity (Standard)	kW	12/18	18	21,9
Steam	bar	1-8	1-8	1-8
Hot Water	°C	90	90	90
Sound Pressure Level	dB (A)	<65	<65	<65
Water Valves Connection	BSP	3/4"	3/4"	3/4"
Water Pressure	kPa	100-800	100-800	100-800
Rec. Water Pressure	kPa	300-500	300-500	300-500
Water Inlet	l/min	20	20	20-50
Drain Valve	outer Ø mm	76	76	76
Flow Amount with Drain Valve	l/min	210	210	210
Steam Valve Connection	BSP	1/2"	1/2"	1/2"
Steam Pressure	kPa	100-800	100-800	100-800
DIMENSIONS				
Size HxWxD	mm	1410x970x970	1410x970x1105	1410x970x1185
TRANSPORT DATA				
Gross	kg	395	450	515
Net	kg	380	430	495
Packed HxWxD	mm	1550x1025x1015	1550x1025x1150	1550x1025x1225

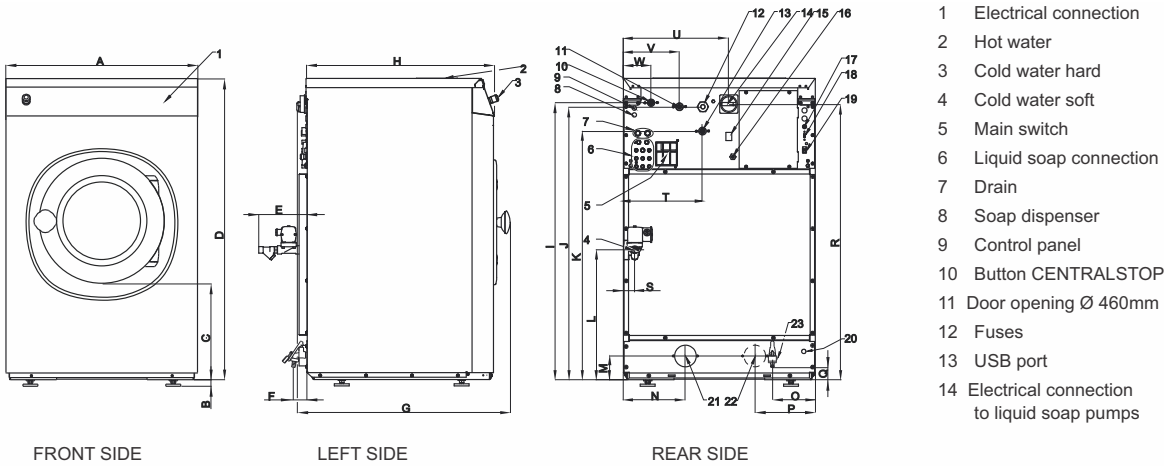

Model	A	B	C	D	E	F	G	H	I	J	K	L	M	N	O
WF180	970	24	477	1410	90	48	970	876	1320	1297,5	1215	490	108,5	270	203
WF240	970	24	477	1410	90	48	1105	1011	1320	1297,5	1215	490	108,5	270	203
WF280	970	24	477	1410	90	48	1185	1086	1320	1305	1215	490	108,5	270	203
	Width			Height			Depth								

