



SAPPHIRE
COMMERCIAL LAUNDRY EQUIPMENT

Sales - Rentals - Parts
info@sapphirelaundry.co.uk
www.sapphirelaundry.co.uk



WF 65 / WF 80 WF 105 / WF 135



Features

- Freestanding, high spin (1165 RPM - WF 65, 80)
- Stainless steel top panel & anthracite grey front and side panels
- Stainless steel drum and tub
- Basic - easy-to-use microprocessor
- Patented soap hopper
- Large drain valve (Ø 76mm)
- Easy access to all vital parts from the front
- Large door opening for easy loading & unloading

Options

- Professional control - Fully programmable
- Coin operated timer (CPS)
- Stainless steel front and side panels
- USB plug (on the back panel)
- Liquid soap print (8x 24V AC Signals) - Liquid soaps connection
- Liquid soap pumps
- Water recovery kit
- Steam heating version
- Drain pump (WF 65, 80)
- 175 G-factor execution
- 7mm drum holes
- Automatic door opening in case of power failure



Dimensions & Specifications

Type		WLS 25	WSMS 13	WLS 30	WLS D 30
INNERDRUM					
Maximum Capacity 1:9	kg	7	9	12	15
Capacity 1:10	kg	6,5	8	11	14
Volume	litres	65	75	105	135
Diameter	mm	530	530	620	620
DRUM SPEED					
Wash	rpm	49	49	49	49
Extraction	rpm	1165	1165	1075	1075
G-FACTOR		400	400	400	400
HEATING					
Electricity (Standard)	kW	6/9	6/9	6/9/12	9/12
Steam	bar	1 - 8	1 - 8	1 - 8	1 - 8
Hot Water	°C	90	90	90	90
Sound Pressure Level	dB (A)	< 65	< 65	< 65	< 65
Water Valves Connection	BSP	3/4"	3/4"	3/4"	3/4"
Water Pressure	kPa	100-800	100-800	100-800	100-800
Rec. Water Pressure	kPa	300-500	300-500	300-500	300-500
Water Inlet	l/min	20	20	20	20
Drain Valve	outer Ø mm	76	76	76	76
Flow Amount with Drain Valve	l/min	210	210	210	210
Steam Valve Connection	BSP	1/2"	1/2"	1/2"	1/2"
Steam Pressure	kPa	100-800	100-800	100-800	100-800
DIMENSIONS					
Size HxWxD	mm	1115x710x740	1115x710x790	1225x795x795	1225x795x945
TRANSPORT DATA					
Gross	kg	180	200	235	275
Net	kg	170	185	210	255
Packed HxWxD	mm	1245x750x840	1245x750x840	1345x835x840	1345x835x985

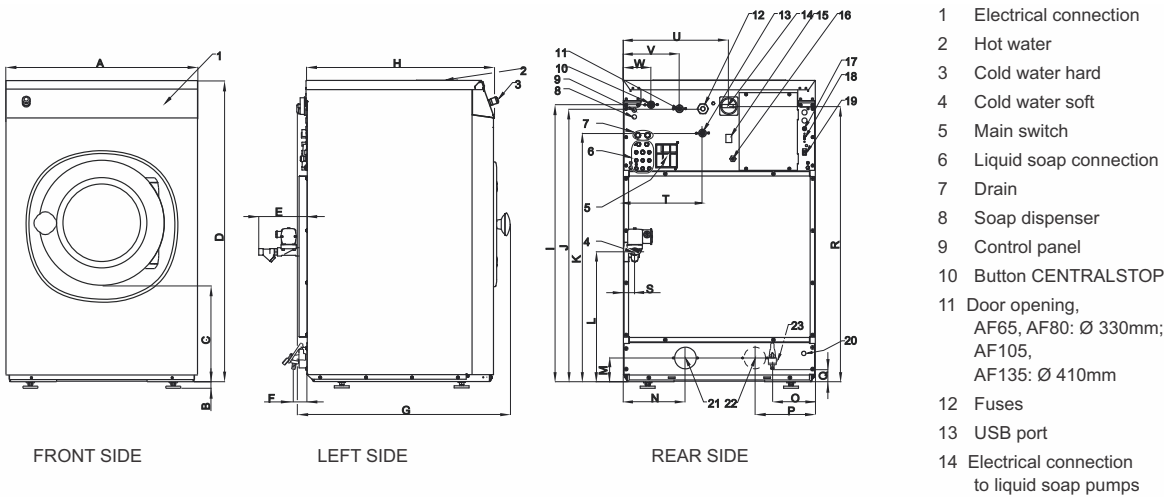

Model	A	B	C	D	E	F	G	H	I	J	K	L	M	N	O
WF 65	710	24	349	1115	180	48	740	646	1019	1004	914	480	82	230	203
WF 80	710	24	349	1115	180	48	790	696	1025	1010	920	480	88	230	203
WF 105	795	24	342	1225	180	48	795	696	1135	1120	1030	506	88	230	203
WF 135	795	24	342	1225	180	48	945	846	1135	1120	1030	506	88	230	203
	Width			Height			Depth								

		WF80
Water Consumption	l/kg	7,2
Electricity Consumption	kWh/kg	0,19

* Program number 11



Sales - Rentals - Parts
info@sapphire laundry.co.uk
www.sapphire laundry.co.uk

