



SAPPHIRE
COMMERCIAL LAUNDRY EQUIPMENT

Sales - Rentals - Parts
info@sapphirelaundry.co.uk
www.sapphirelaundry.co.uk



WR 180 / WR 240 WR 280



Features

- Rigid mounting, normal spin, 100 G
- Stainless steel top panel, anthracite grey front and side panels
- Stainless steel drum and tub
- Basic control - easy-to-use microprocessor
- Patented soap hopper
- Large drain valve (Ø76mm)
- Easy access to all vital parts from the front
- Large door opening for easy loading and unloading

Options

- Professional control - Fully programmable
- Coin operated timer (CPS)
- Stainless steel front and side panels
- USB plug (on the back panel)
- Liquid soap print - Liquid soap connection
- Liquid soap pumps
- Water recovery kit
- Steam heating version
- High capacity water inlets (WR 180 - WR 240)
- 175 G-factor execution
- 7mm drum holes (WR 180 - WR 240)
- Automatic door opening in case of power failure



Dimensions & Specifications

Type		WR 180	WR 240	WR 280
INNERDRUM				
Maximum Capacity 1:9	kg	20	27	31
Capacity 1:10	kg	18	24	28
Volume	litres	180	240	280
Diameter	mm	750	750	750
DRUM SPEED				
Wash	rpm	42	42	42
Extraction	rpm	490 (100G) - 645 (175G)	490 (100G) - 645 (175G)	490 (100G) - 645 (175G)
G-FACTOR		100 (optional 175)	100 (optional 175)	100 (optional 175)
HEATING				
Electricity (Standard)	kW	12	18	21,9
Steam	bar	1-8	1-8	1-8
Hot Water	°C	90	90	90
Sound Pressure Level	dB (A)	<65	<65	<65
Water Valves Connection	BSP	3/4"	3/4"	3/4"
Water Pressure	kPa	100-800	100-800	100-800
Rec. Water Pressure	kPa	300-500	300-500	300-500
Water Inlet	l/min	20	20	20
Drain Valve	outer Ø mm	76	76	76
Flow Amount with Drain Valve	l/min	210	210	210
Steam Valve Connection	BSP	1/2"	1/2"	1/2"
Steam Pressure	kPa	100-800	100-800	100-800
DIMENSIONS				
Size HxWxD	mm	1410x890x915	1410x890x1060	1410x890x1135
Net Weight	kg	255	275	290
TRANSPORT DATA				
Bruto Weight	kg	270	290	305
Packing Dimensions	mm	1550x925x970	1550x925x1130	1550x925x1190

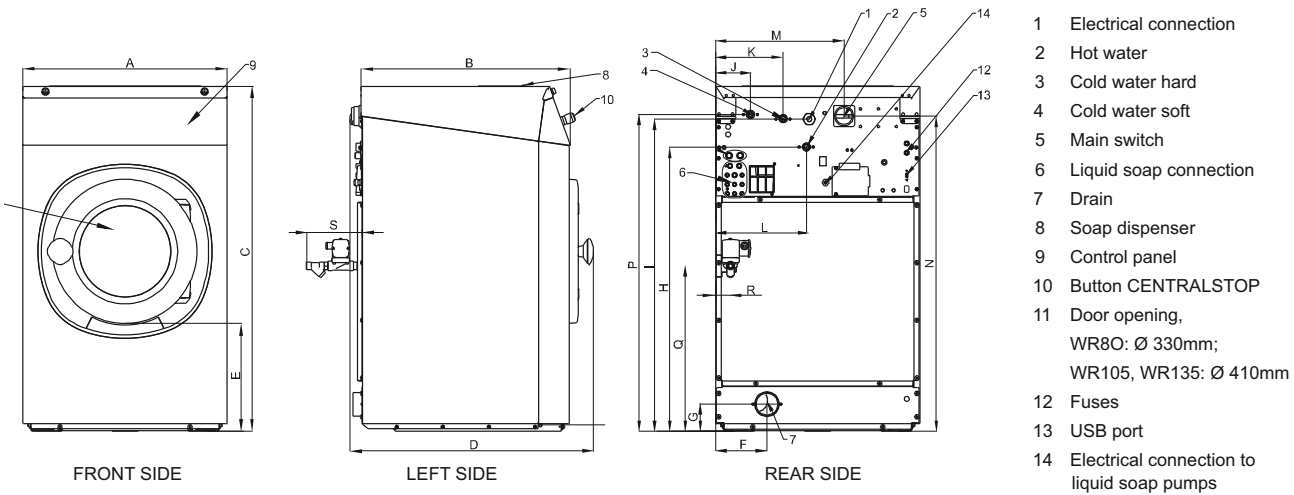

Model	A	B	C	D	E	F	G	H	I	J	K	L	M	N	P	Q	R	S
WR 80	890	915	1410	815	465	280	130	1212	1297	113	218	303	625	1270	1317	528	54	120
WR 105	890	1060	1410	960	465	280	130	1212	1297	113	218	303	625	1270	1317	528	54	120
WR 135	890	1135	1410	1035	465	280	130	1212	1297	113	218	303	625	1270	1317	528	54	120
	Width	Height	Depth															



Sales - Rentals - Parts
info@sapphire laundry.co.uk
www.sapphire laundry.co.uk

